

**RESIDENTIAL
ASPHALT
FOOTPATH (RAF)**

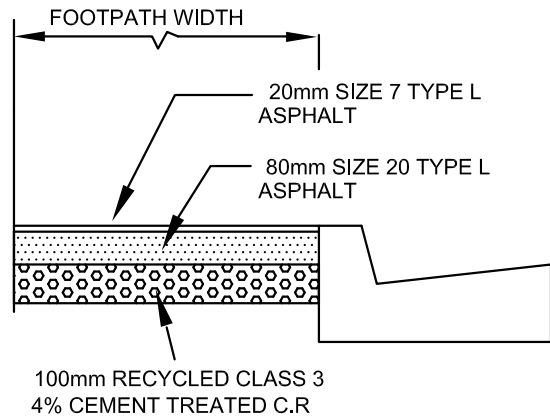

**INDUSTRIAL
ASPHALT
FOOTPATH (IAF)**

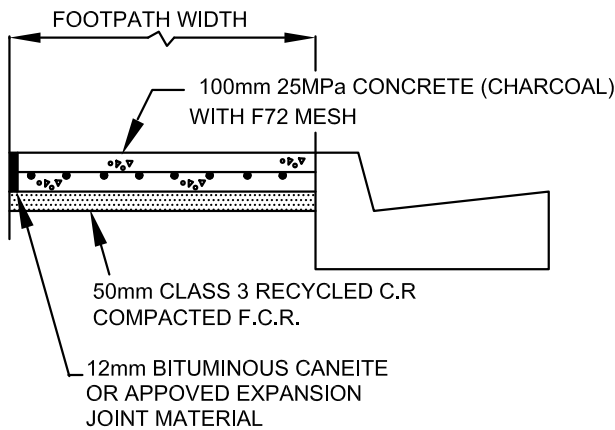

CONCRETE FOOTPATH (CF)

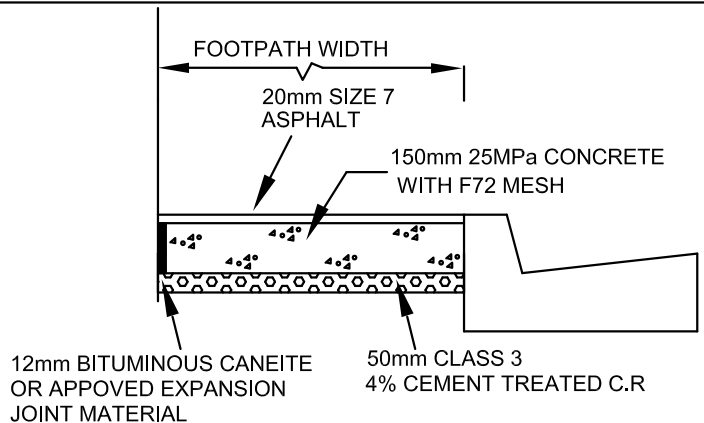

**INDUSTRIAL CONCRETE
FOOTPATH WITH ASPHALT
SURFACE (ICAF)**

GENERAL NOTES

1. FOOTPATH CROSS FALLS SHALL NOT BE FLATTER THAN 1:80 (1.2%) OR STEEPER THAN 1:40 (2.5%). CROSS FALLS GREATER OR LESS THAN SHOWN MUST BE APPROVED BY COUNCIL'S SUPERVISING OFFICER.
2. TO BE READ IN CONJUNCTION WITH COUNCIL SPECIFICATIONS
3. TYPE OF FOOTPATH TO BE AGREED BY COUNCIL ENGINEER.
4. AT ALL TIMES FOOTPATH WORKS SHALL NOT REDUCE PEDESTRIAN SAFETY. ADEQUATE SAFETY MEASURES MUST BE INSTALLED.
5. REFER YSD 402 -- FOOTPATH DETAILS FOR RETAIL STRIPS.
6. ALL CONCRETE SHALL BE 25 MPa AT 28 DAYS (TO BE CHARCOAL COLOUR AT THE RATIO OF 1 BAG (25kg) FOR EVERY CUBIC METRE OF CONCRETE).
7. FOR (CF) & (ICAF) FOOTPATH - PROVIDE DUMMY JOINTS AT INTERVAL OF 1.5m AND EXPANSION JOINTS @ 15m. DUMMY JOINTS SHALL BE FINISHED WITH APPROVED JOINTING TOOL TO GIVE A NEAT GROOVE AT LEAST 6mm DEEP BY 3mm WIDE NORMAL TO THE PAVEMENT EDGE.

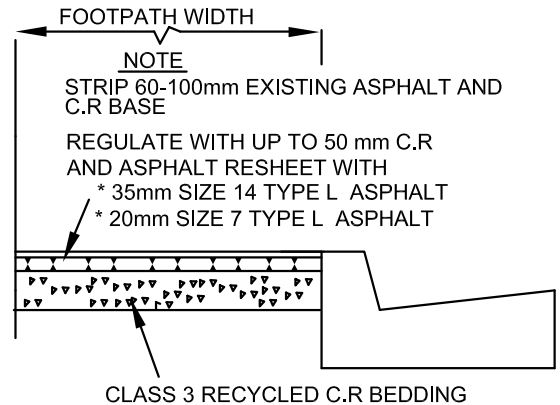

**RESIDENTIAL FOOTPATH
STRIP AND RESHEET**

Yarra Standard: YSD401
Drawing Title:
TYPICAL FOOTPATH DETAILS

Scale at A4 N.T.S

REV	DATE	DRAWN BY
A	08/10/09	HL
B	30/04/12	DKC
C	28/05/18	HL
D	02/10/18	HL
E	10/09/24	HL

