

THIS DISTANCE
MAY BE ALTERED
AT THE DISCRETION
OF THE REINSTATEMENT
OFFICER

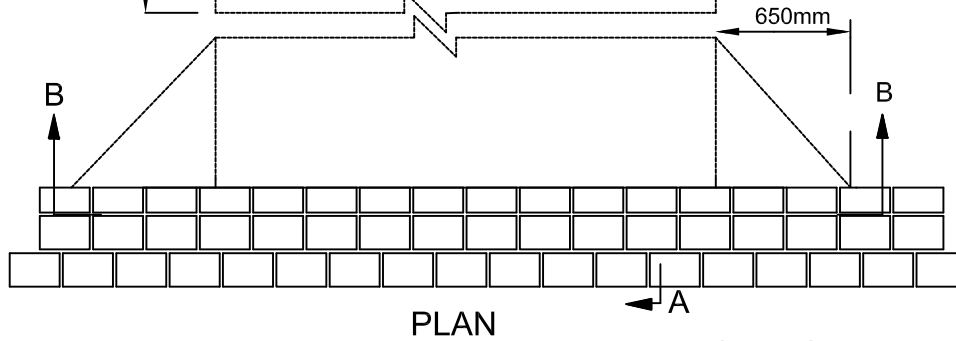

PLAN

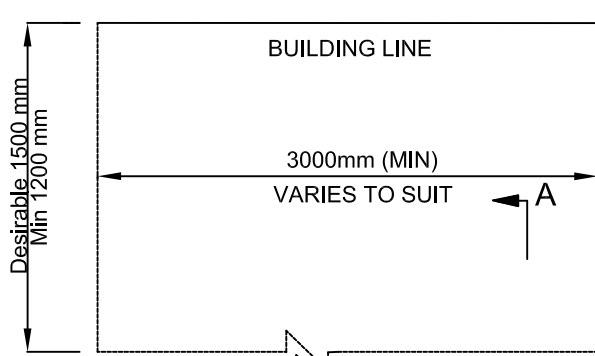
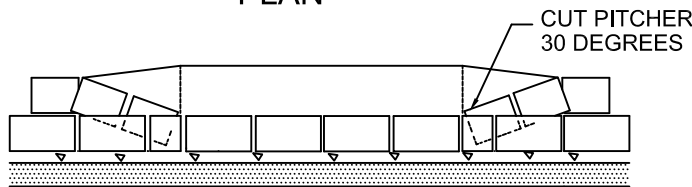

SECTION B-B

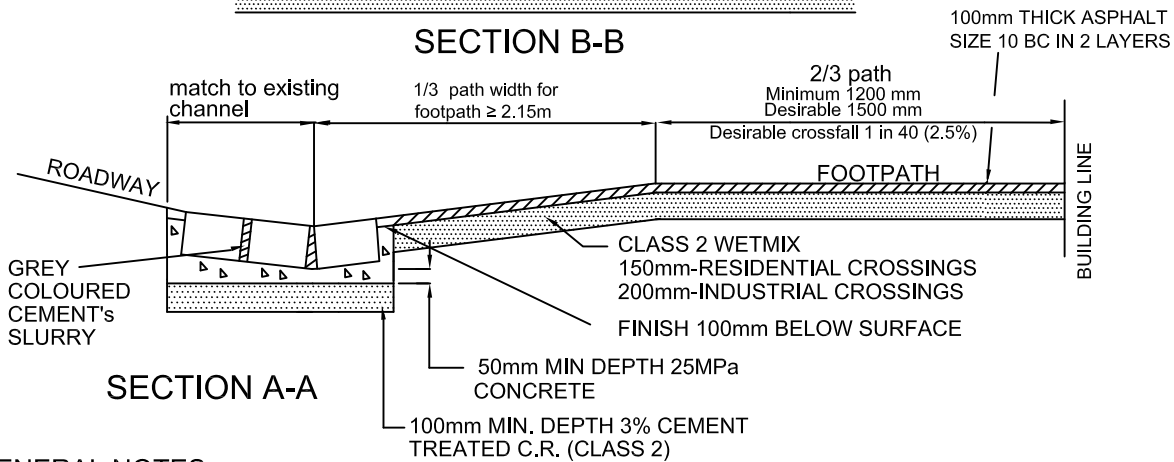

SECTION A-A

GENERAL NOTES

1. HOUSE/PROPERTY DRAINS TO BE RELOCATED CLEAR OF CROSSING AREA.
2. EDGE OF SPLAY OF CROSSING SHOULD BE WITHIN 1m CLEAR OF POWERPOLE & 300mm CLEAR OF EDGE OF PIT LINTEL.
3. BLUESTONE JOINTS TO BE NOM. 15mm.
4. THIS DRAWING IS TO BE READ IN CONJUNCTION WITH COUNCIL'S SPECIFICATIONS.
5. SEE STANDARD DRAWINGS FOR DRESSED PITCHER KERB AND CHANNEL DETAILS.
6. CEMENT TREATED CRUSHED ROCK TO BE LAID WITHIN 15 MINUTES ARRIVAL ON SITE.
7. UNUSED BLUESTONES REMOVED FROM THE CHANNEL ARE TO BE RETURNED TO COUNCIL DEPOT.
8. INVERT TO BE FINISHED TO GRADE WITH WOODEN FLOAT.
9. ADEQUATE GROUND CLEARANCE MUST BE PROVIDED AS PER AS2890.1-2004 FOR THE 99th PERCENTILE VEHICLE AT ALL CARPARKS OTHER THAN THOSE ON DOMESTIC PROPERTIES.*
* A DOMESTIC PROPERTY IS A PROPERTY COMPRISING OF THREE OR LESS DOMESTIC UNITS.
10. FOR DOMESTIC PROPERTIES THE PROFILE MUST SATISFY THE 85th PERCENTILE VEHICLE AS PER AS2890. 1-2004.
11. WHERE SIGNIFICANT LEVEL CHANGE TO THE EXISTING FOOTPATH IS REQUIRED, ADDITIONAL LEVEL DESIGN ON EITHER SIDE OF THE PROPOSED VEHICLE CROSSING WILL BE NECESSARY.
12. A BULL NOSE OF UP TO 60mm AT THE FACE OF KERB WILL BE ALLOWED IF REQUIRED TO SATISFY THE AS2890.1-2004.

Yarra Standard: YSD602
Drawing Title:
**STANDARD BLUESTONE
VEHICLE CROSSING**

Scale at A4 N.T.S

| REV | DATE | DRAWN BY |
|-----|----------|----------|
| A | 30/04/12 | DKC |
| C | 05/05/16 | CA |
| B | 11/07/17 | HL |
| | | |
| | | |

